

Kovanje

Prof. dr. sc. Milan Opalić

TEHNOLOGIČNO OBLIKOVANJE

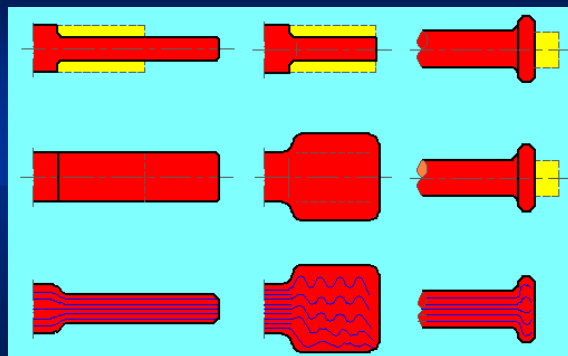

Osnovni postupci pri slobodnom kovanju

Prof. dr. sc. Milan Opalić

TEHNOLOGIČNO OBLIKOVANJE

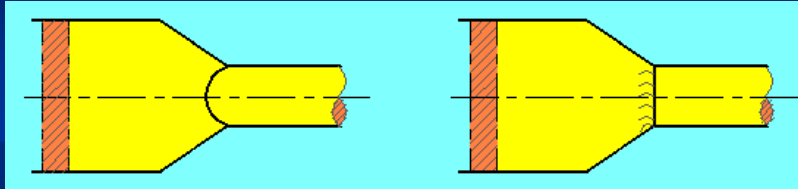

Zavari umjesto kovanja

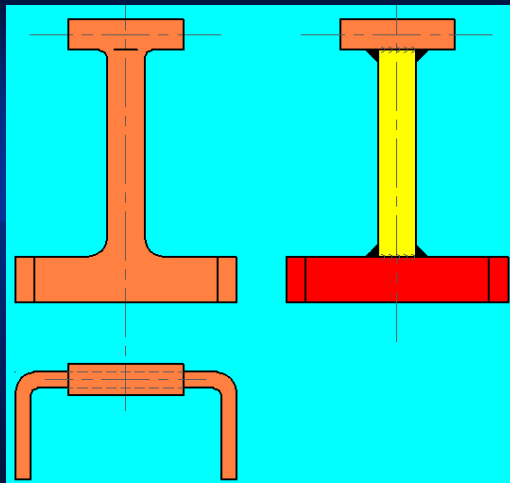

Zavarivanje je često jeftinije od kovanja

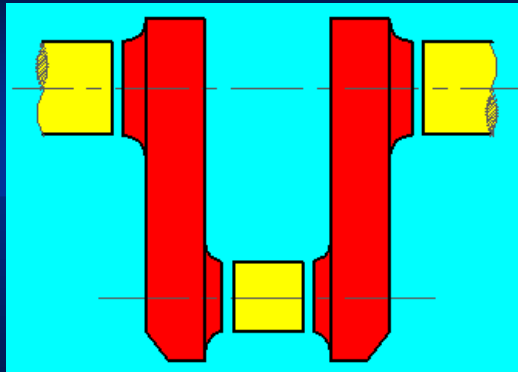

Elektrotoporno zavareno vratilo manjih dimenzija

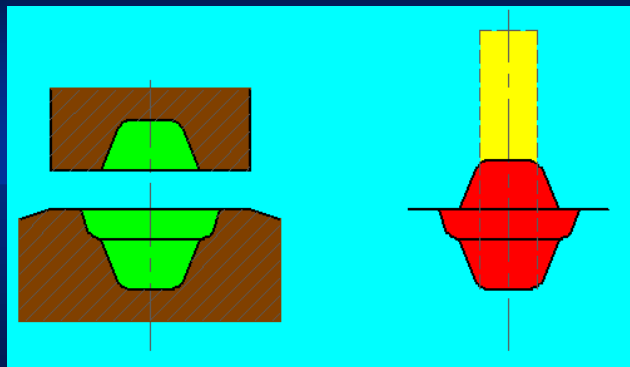

Sabijanje pri kovanju u ukovnju

Granica ekonomičnosti kovanja ručice u ukovnju

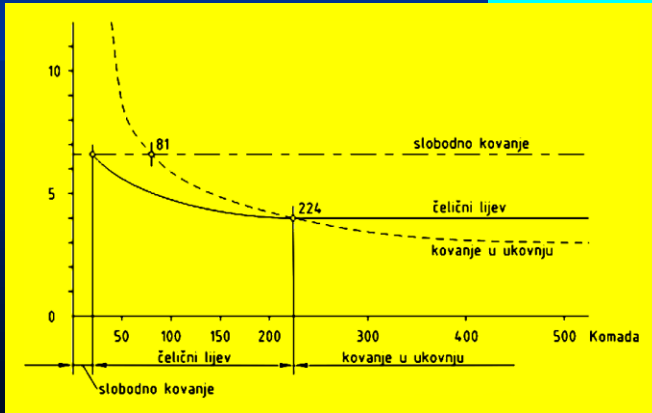
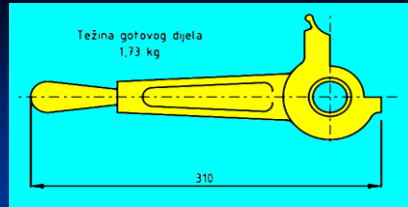

Prof. dr. sc. Milan Opalić

TEHNOLOGIČNO OBLIKOVANJE

Učestalost troškova materijala, težine materijala i troškova obrade pri izradi zupčanog prigona u postocima

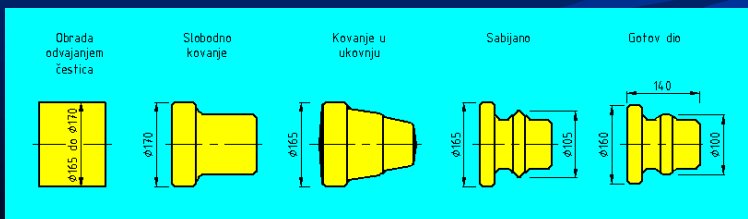
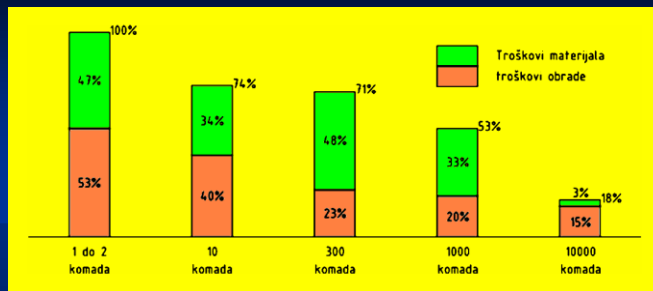

Prof. dr. sc. Milan Opalić

TEHNOLOGIČNO OBLIKOVANJE

Oblikovanje slobodno kovane ručice

- a) kovački nepogodan oblik
- b) kovački pogodniji oblik
- c) mogućnost pojeftinjenja izrade

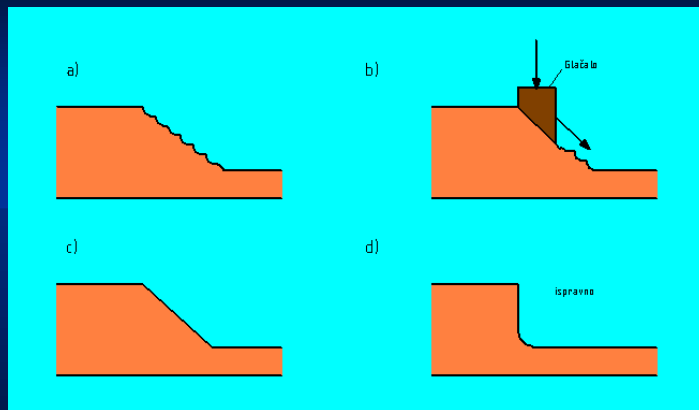
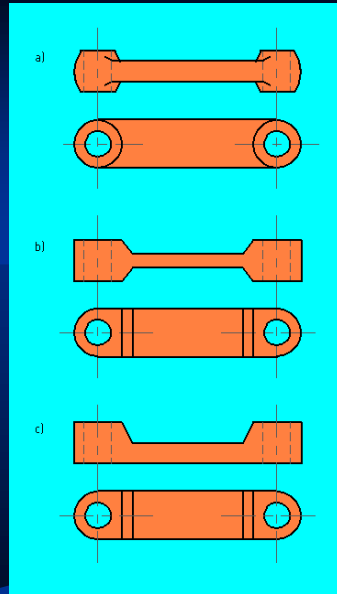

Izbjegavanje strmih prijelaza

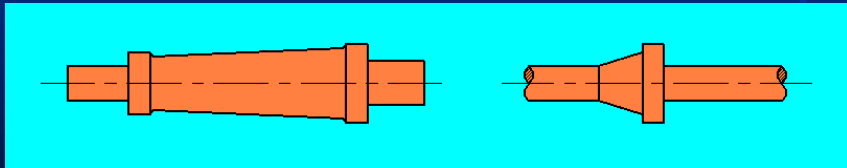
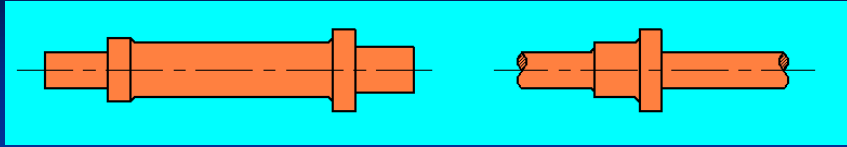

Izbjegavanje stožastih prijelaza

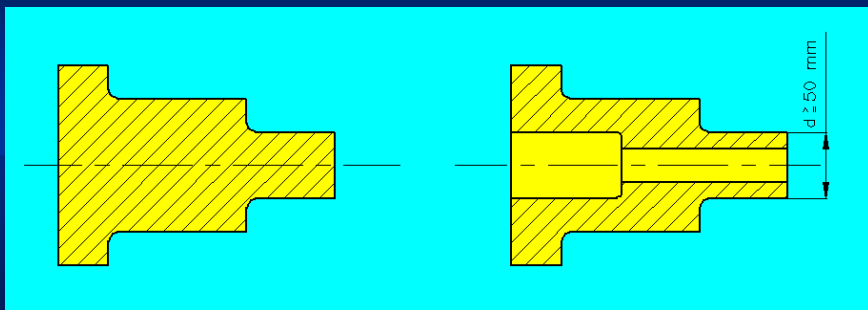

Teški otkivci moraju biti šuplji

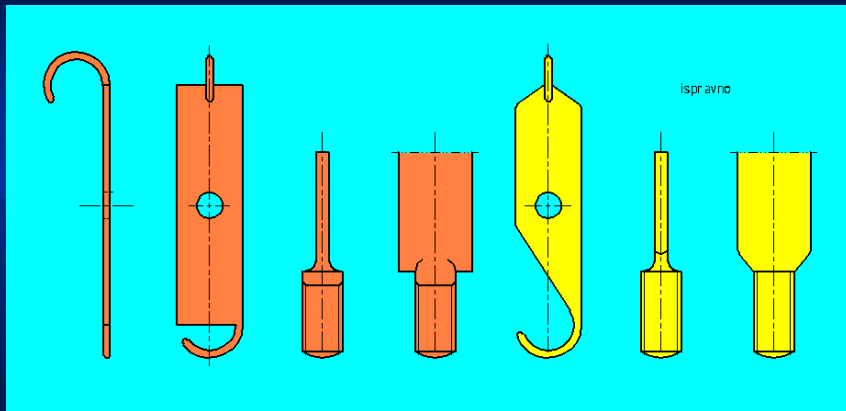

Oštre prijelaze presjeka treba izbjegavati

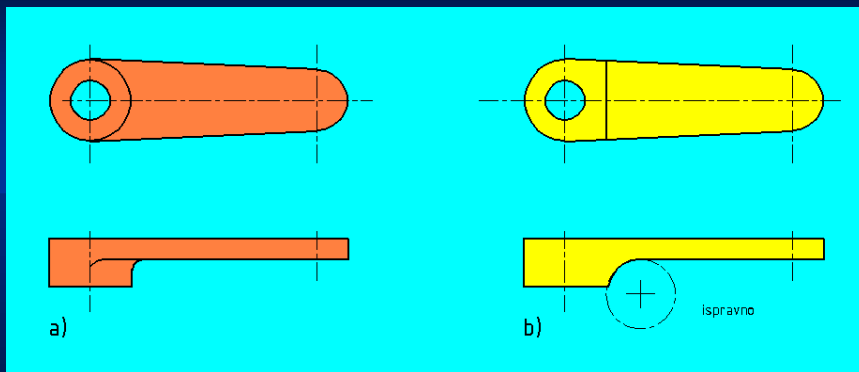

Okrugla oka na jednokratnoj ručici valja izbjegavati

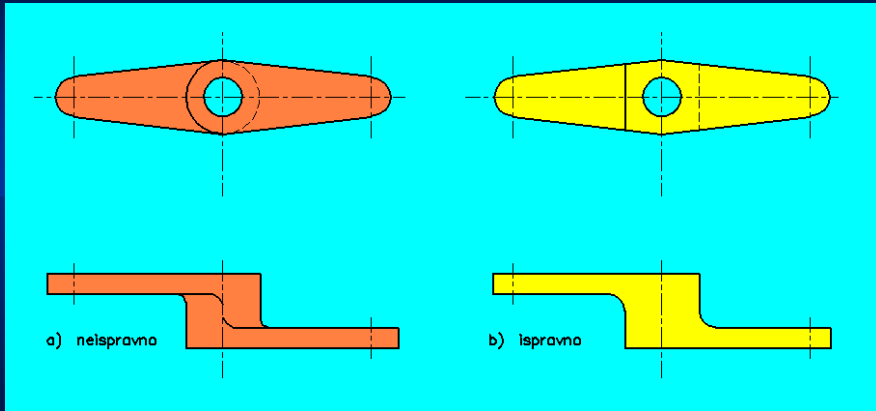

Okrugla oka na dvokrakoj ručici potrebno je izbjegavati

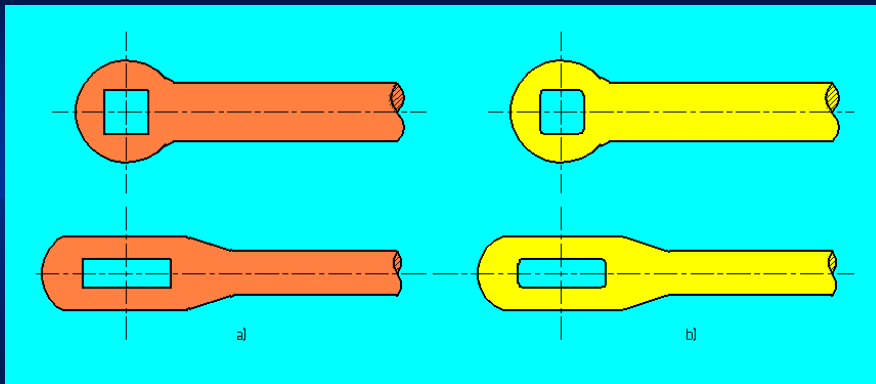

Oštre kutove na četverokutnim rupama i prorezima valja izbjegavati

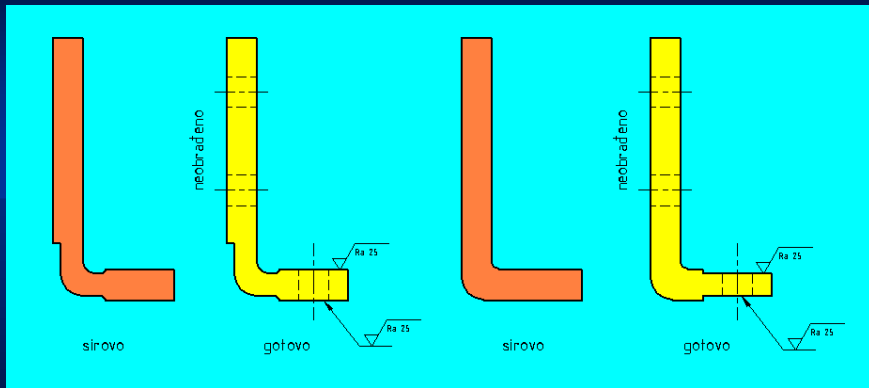

Kovanje kutnika iz tanjeg materijala sabijanjem i iz debljeg i stanjivanjem pomoću obrade

Prof. dr. sc. Milan Opalić

TEHNOLOGIČNO OBLIKOVANJE

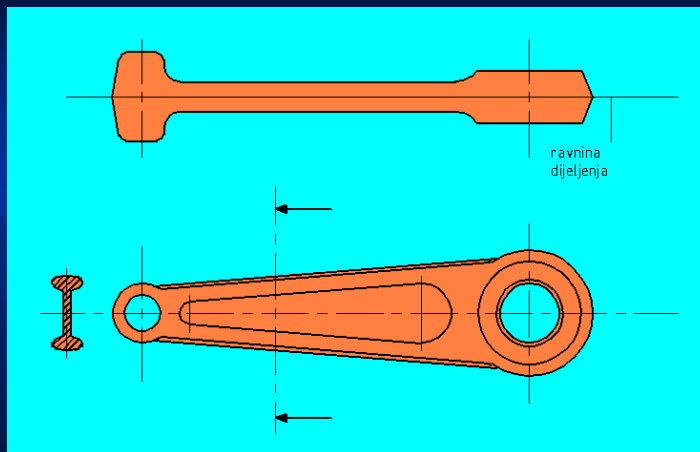

Ojnica motora kovana u ukovnju

Prof. dr. sc. Milan Opalić

TEHNOLOGIČNO OBLIKOVANJE

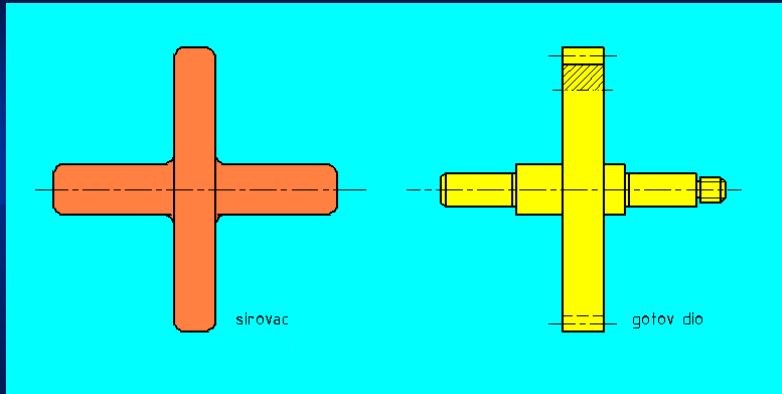

Zupčanik s vratilom kovan u ukovnju

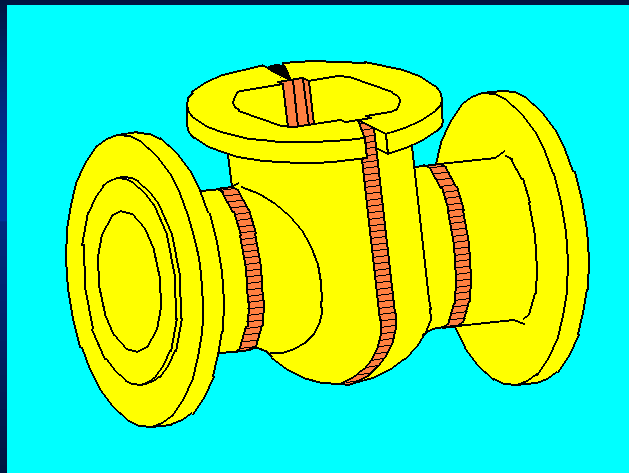

Otkovak kovan u ukovnju i dijelovima i zavaren

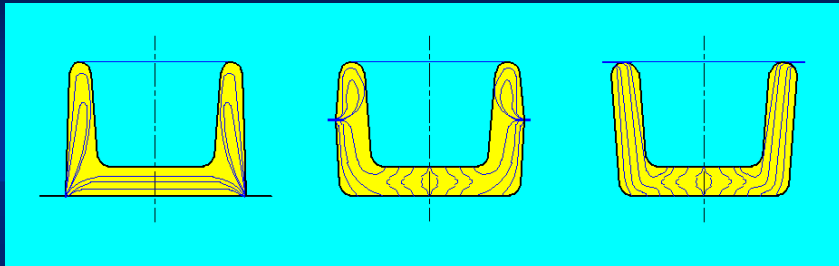

Mogući tok strukturnih linija

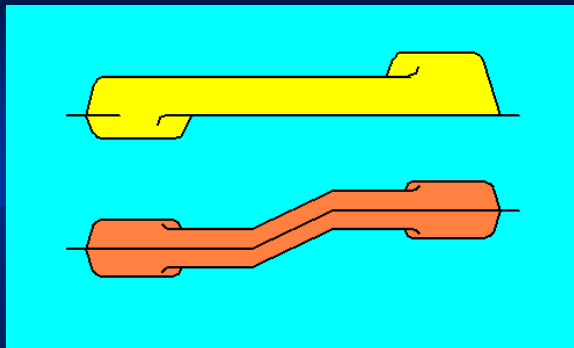

Razdjelna reška mora ležati u jednoj ravnini

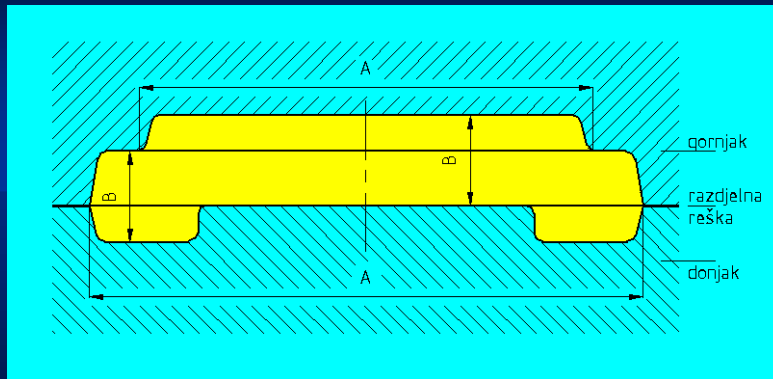

- A) mjere i oblik određene jednom polovicom alata (točne mjere i oblik)
- B) mjere određene objema polovicama alata

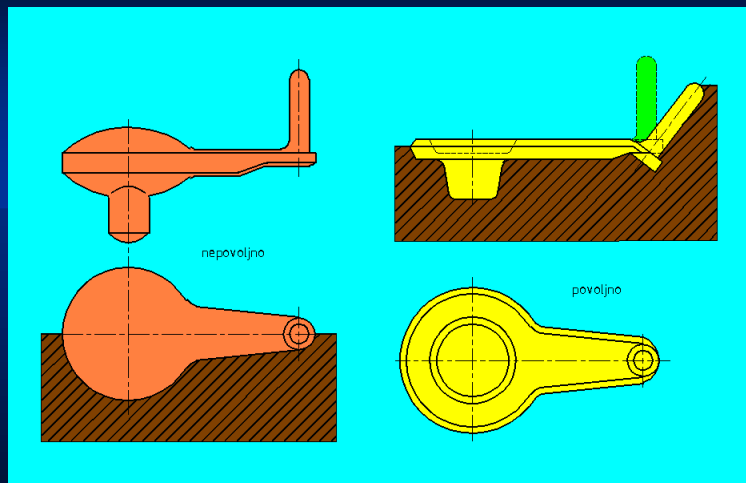

Naknadno savijanje nakon kovanja u ukovnju

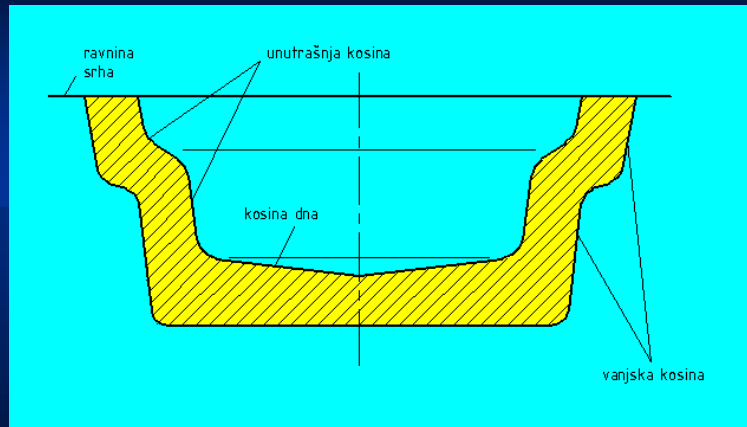

Kosine na dnu otkovka olakšavaju tečenje

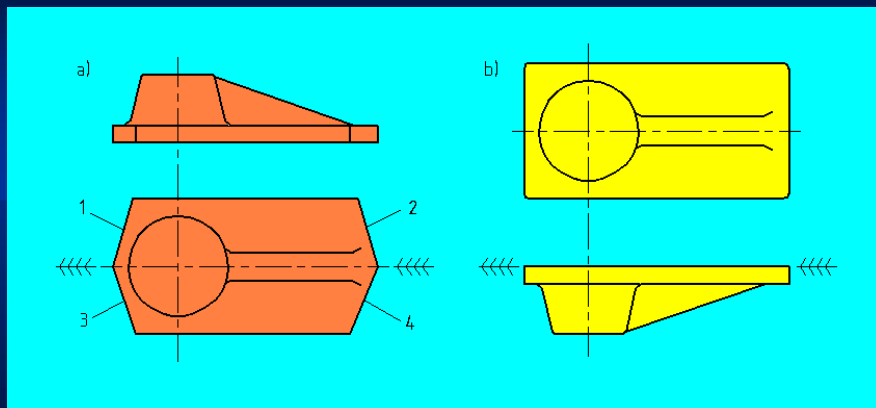

Položaj razdjelne reške

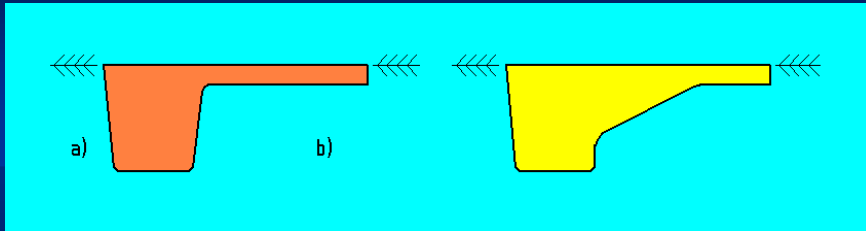

Valja izbjegavati nagle prijelaze presjeka

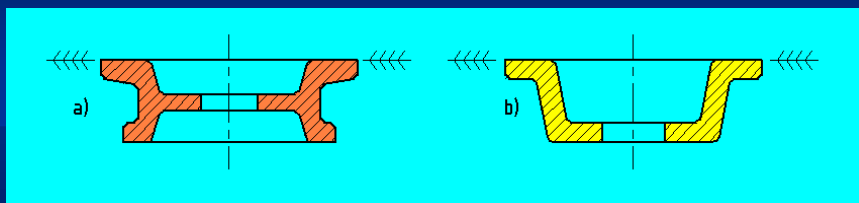

Otkovke s podrezom potrebno je izbjegavati

Pojednostavljanje postignuto
rastavljanjem otkovka
na pojedine dijelove

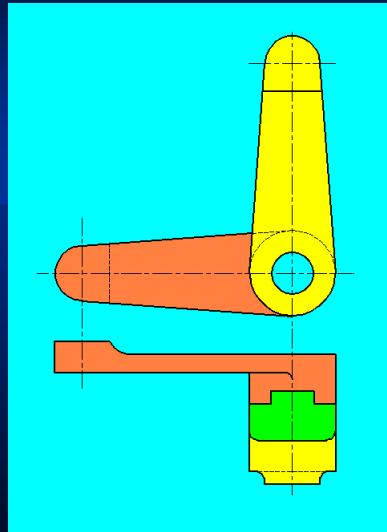

Prof. dr. sc. Milan Opalić

TEHNOLOGIČNO OBLIKOVANJE

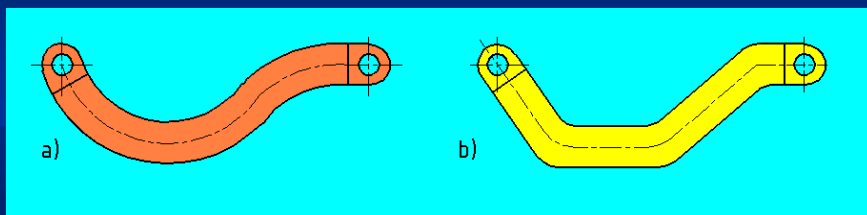

Izbjegavati komplicirane zakrivljenosti dijelova

Prof. dr. sc. Milan Opalić

TEHNOLOGIČNO OBLIKOVANJE

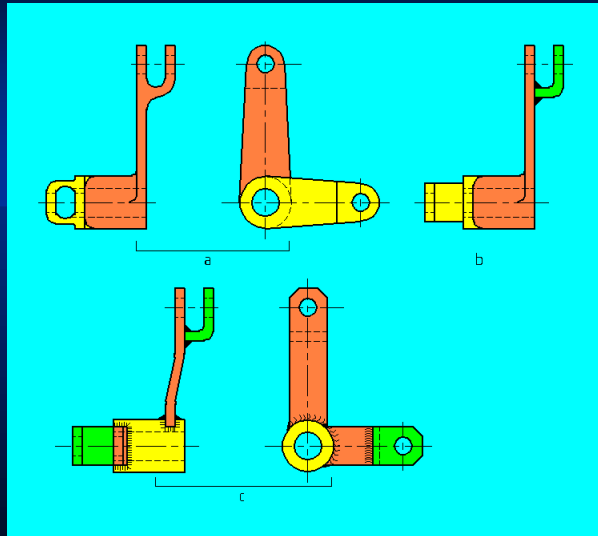

Prof. dr. sc. Milan Opalič

TEHNOLOGIČNO OBLIKOVANJE

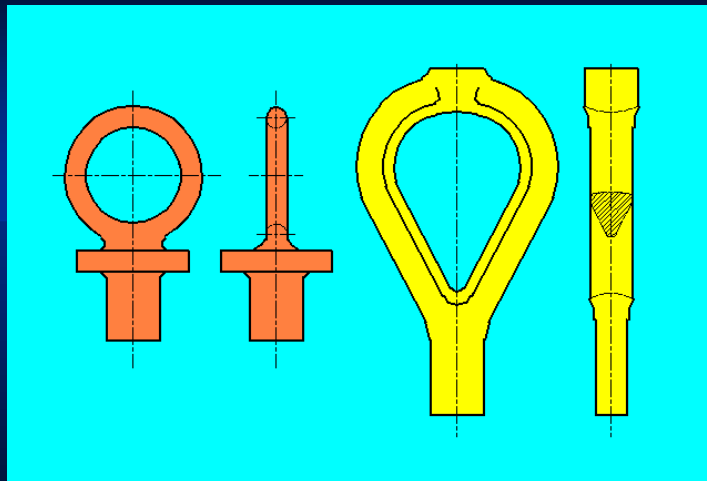

Prstenasti oblici kovani u ukovnju

Prof. dr. sc. Milan Opalič

TEHNOLOGIČNO OBLIKOVANJE

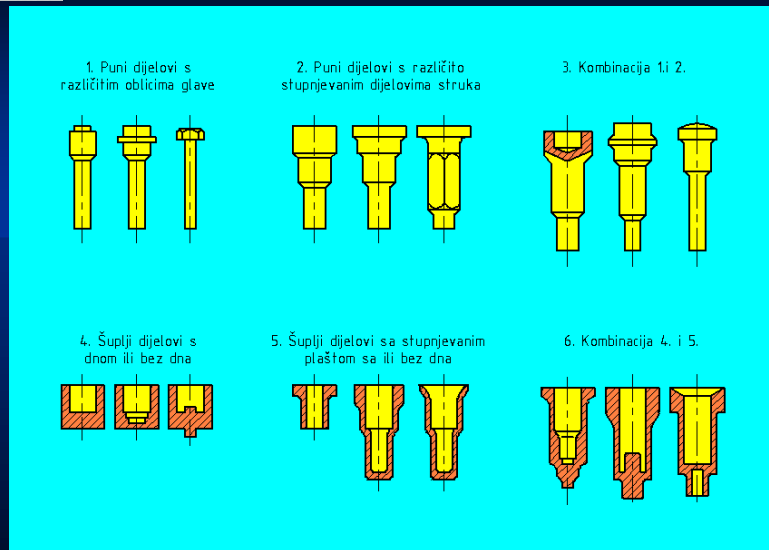

Neki važniji oblici koji se mogu proizvesti ekstrudiranjem

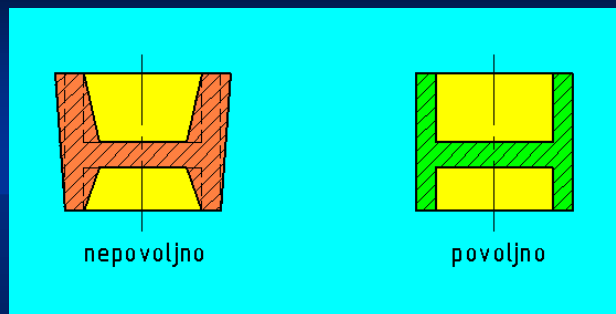

Kosine nisu potrebne

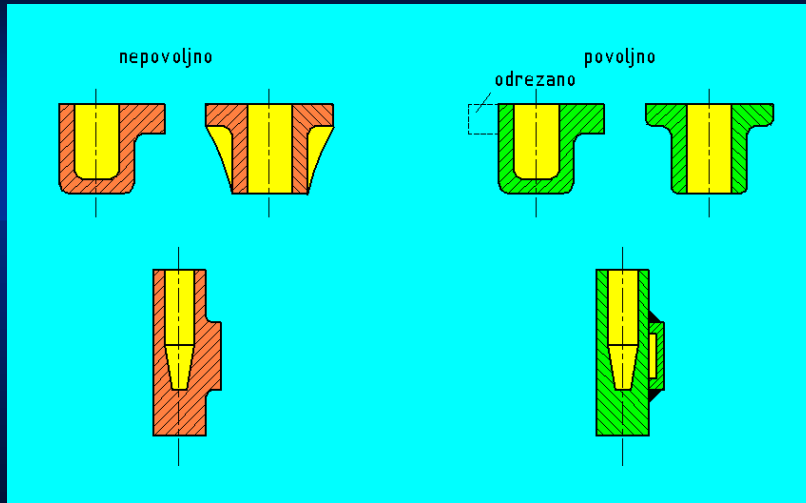

Oblikovati valja simetrično

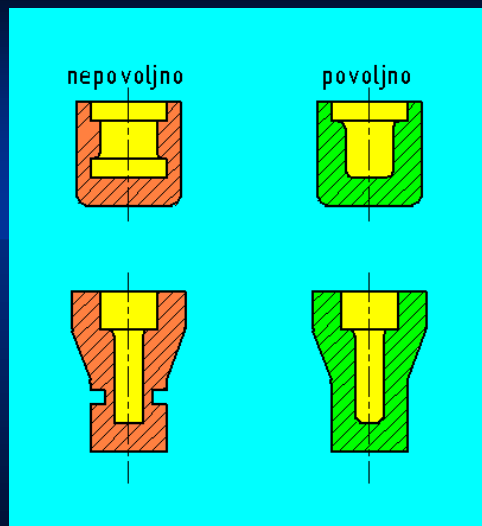

Potrebno je oblikovati bez utora

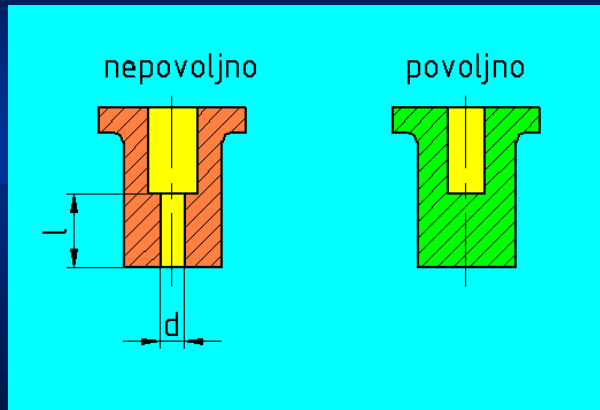

Male rupe ne mogu se proizvesti ekstrudiranjem

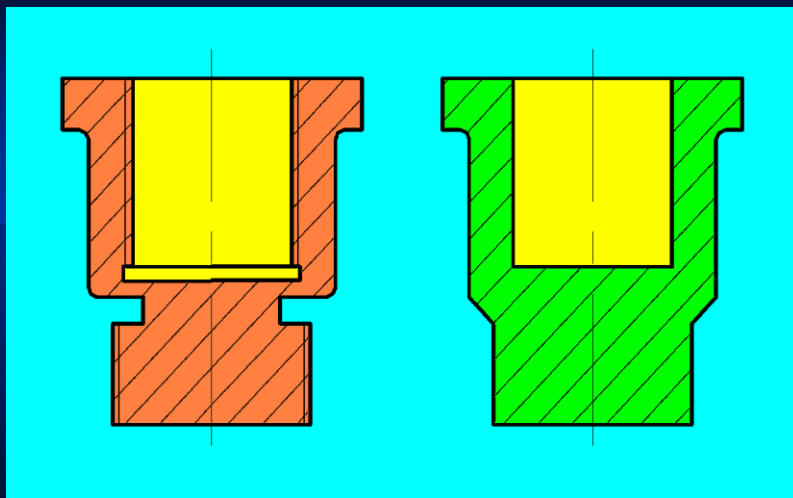

Navoji se ne mogu proizvesti ekstrudiranjem